

STRICTLY CONFIDENTIAL

FOR PHILIPS SERVICE  
DEALERS ONLY

Copyright reserved

# PHILIPS

SERVICE DOCUMENTATION

FOR THE RECEIVER:

## BX 297 U

1949

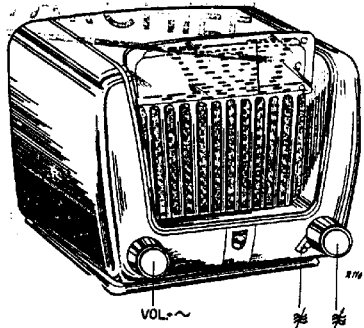

For A.C. and D.C. mains supplies.

### WAVEBANDS

S.W.2 : 13,5 - 28 m (22.22 - 10.7 Mc/s)  
S.W.3 : 30 - 90 m (10 - 3.34 Mc/s)  
M.W. : 187 - 565 m (1604 - 531 kc/s)

### TRIMMING FREQUENCIES

21.6 Mc/s ;  
9.6 Mc/s ;  
1525 kc/s ; 575 kc/s  
I.F. : 452 kc/s

### VALVES AND PILOT LAMP

B1 : UCH42      B4 : UL41  
B2 : UAF42      B5 : UY41  
B3 : UBC41      L1 : 8097-D00

LOUDSPEAKER: Type 9730 X

### KNOBS

Frontside : right side : tuning and waverange switch  
                  left side : mains switch and volume control

### BANDWIDTH

The I.F. bandwidth (1:10) measured from the control grid g1 of B1 is about 12 kc/s. The "overall" bandwidth measured from the aerial socket is at 1000 kc/s : 11.5 kc/s.

### MAINS TENSIONS

Adaptable for 117 and 200 V  $\approx$ . By short-circuiting R4 suited for 200 V  $\approx$  (position 220 V  $\approx$ ).

### CONSUMPTION

45 W ( 220 V  $\approx$  )  
35 W ( 117 V  $\approx$  )

DIMENSIONS

Height: 21 cm.  
Width : 26,5 cm) Knobs included  
Depth : 18 cm)

WEIGHT: Approx. : 3 kg. (valves included)

IMPORTANT

When repairing or trimming a set while it is connected to A.C. mains, a transformer has to be used with separate windings. The secondary winding must not be earthed while only one set may be connected to the transformer at a time. The chassis can then be earthed. The code number of a suitable type of transformer is given in the "List of Parts and Tools". When connecting the set to D.C. mains the connection must be made with the right polarity.

SOME PARTICULARS ABOUT THE PRINCIPLE DIAGRAM

This set has been provided with a frame-aerial which is very effective on M.W., while there is a capacitive aerial for the S.W. bands. When an outdoor aerial is used, both antennas remain connected to their circuits. If no outdoor-aerial is connected and thus the built-in frame-aerial on M.W. is used, C35 is switched parallel to C6. This to compensate the influence of the outdoor-aerial capacity.

TRIMMING

For trimming the set need not be uncased. Only the rear panel and the screening plate, which covers the R.F. part, have to be removed. The latter can be pulled out between the side of the chassis and the cabinet. The oscillator frequency is higher than the signal frequency.

A. I.F. BANDFILTERS

1. Volume control to maximum.
2. Variable condenser to minimum capacity
3. Earth chassis, taking into account the remarks above under "Important".
4. Connect outputmeter via trimming transformer to loudspeaker connections.
5. Apply I.F. signal of about 452 kc/s via a 33000 pF condenser to g1 of B2.
6. Determine the tuning of the 3rd and 4th I.F. circuit.
7. Apply this signal to the control grid g1 of B1 via a condenser of 33000 pF and turn the cores of the 1st and 2nd I.F. circuit as far out as possible.
8. Trim successively to maximum output the 1st and 2nd I.F. circuit.
9. Seal the cores.

REMARK

The iron cores of the I.F. bandfilter are sealed with "vaseline compound" (for code number see "List of Parts and Tools"). This compound does not require heating for making adjustments, because it can be removed in the cold state with a screw-driver.  
HEATING OF THE CORES DAMAGES THE COREHOLDER AND MAKES ADJUSTMENT IMPOSSIBLE.

B. H.F. AND OSCILLATOR CIRCUITS

1. Volume control to maximum. Earth the chassis taking into account the remarks above under "Important".
2. Connect outputmeter via trimming transformer to loudspeaker connections.
3. Turn the variable condenser on minimum, adjust the pointer to the zeropoint on the dial. If necessary unscrew the fixing screw on the pointer and readjust the position of the pointer.
4. Waverangeswitch at M.W. Pointer on trimming point at 1525 kc/s (15°). Apply a modulated signal at 1525 kc/s to the aerial socket via dummy aerial. Trim respectively at maximum output C21 and C11. Pointer on trimming point at 575 kc/s (521.7 m), apply a modulated signal of 575 kc/s to the aerial socket via dummy aerial. Trim at maximum output C18. Pointer back on trimming point at 1525 kc/s (15°) and feed in a modulated signal of 1525 kc/s to the aerial socket. Adjust C21 for maximum output.
5. Waverangeswitch at S.W.3. Pointer on trimming point at 9,6 Mc/s (23°). Apply a modulated signal of 9,6 Mc/s to the aerial socket via dummy aerial. Trim C12 at maximum output.
6. Waverangeswitch at S.W.2. Apply a modulated signal of 21,6 Mc/s to the aerial socket via dummy aerial. When tuning the set to this signal, chose the peak involving the lowest wavelength.
7. Adjust the trimmer C10 to maximum output. During the alignment of C10 it might be necessary to retune the Service Oscillator slightly to compensate the influence of C10 to the oscillator circuit of the set.
8. Finally seal all the trimmers with Superlawax.

REPAIRS AND REPLACEMENTS OF PARTSDECASING THE CHASSIS

1. Remove the rear panel.
2. Remove control knobs - tuning and volume control.
3. Unscrew pointer from driving cable.
4. Unsolder the loudspeaker connections as the connection to the capacitive aerial (above the loudspeaker).
5. Remove 2 screws at the bottom side and two at top side of the cabinet.
6. Draw the chassis out of the cabinet.

N.B.

After having uncased the chassis, the lever knob of the wave-range switch can be taken out of the cabinet carefully.

DRIVING CABLE

The path of the driving cable is shown in fig.7. The variable condenser here stands in its minimum position. The length of the driving cords are 622 mm and 580 mm.

RENEWAL OF THE LOUDSPEAKER CONE

1. Cut off the clamping ring and draw out the old cone from the cone carrier.
2. Clean the air gap and put a paper ring over the carrier.

3. Rub in the special glue on the cone carrier.  
It is of importance not to use any other adhesive because the joint between the linen centering ring and the cone carrier has to answer heavy demands.
4. Insert the speaker coil together with a small piece of celluloid in the air gap.
5. Press the linen centering ring well up against the cone carrier and let it dry for at least one hour.
6. Put on the second paper ring, fix the clamping ring and remove the celluloid.

The cone should then be properly centered, otherwise the procedure must be repeated. Finally glue on the linen disc over the opening of the speaker coil.

For code numbers of glue and celluloid see "List of Parts and Tools".

A piece of film of 5,5 x 3 cm. and 0,15 mm thickness can be used for the celluloid.

#### CABINET

The philite cabinet is supplied without transparent emblem. This emblem has to be ordered separately and must be fixed to the cabinet by means of a special glue.

The code numbers are as follows:

Transparent emblem	23 654 14
Special glue	Z 050 00

#### CURRENTS AND TENSIONS

			Vf	Va	Vg2(4)	Vk	Ia	Ig2(4)
UCH42	B1	Triode Heptode	114	95 165	- 65	- -	2,6 2,4	- 3,6
UAF42	B2		12,6	165	65	-	5	1,4
UBC41	B3		12,6	55	-	-	0,25	-
ULA1	B4		45	170	165	9	53	10
UY1	B5		31	-	-	-	-	-
			V	V	V	V	mA	mA

V<sub>C1</sub> : 190 V

V<sub>C2</sub> : 165 V

The above mentioned values were measured with the GM 4257, the set switched to M.W., no signal applied to the aerial, mains tension 220 V.

In the principle diagram the waverange switch is drawn in the S.W. 2 position. The sequence of switching is: S.W.2, S.W.3, M.W.

Fig.	Pos.	Description	Code number
1	1	Cabinet - 038	23 642 14.0
		Rear panel	A3 690 11.0
	Bracket for fixing rear panel	A3 467 62.1	
	Knob - tuning - 038	23 608 14.4	
	Knob - volume control - 038	23 608 21.0	
	Lever knob - waverangeswitch - 038	23 648 61.0	
	2	Fixing bracket - coilcan	28 072 64.2
		Switch segment 1	A3 200 09.1
	3	Switch segment 2	A3 200 10.3
		Pilot lampholder	A3 359 07.0
		Plug socket plate	A3 340 13.0
		Voltage adaptor plate	A3 227 70.0
		Knob for voltage adaptor plate (111)	A3 364 73.0
		Rubber grommet under variable condenser	49 922 26.2
		Tuning spindle	A3 333 01.3
		Spindle of the volume control	A3 426 80.0
		Grubscrew for same	A3 324 16.0
		Variable condenser with drum	49 001 33.0
		Tension spring in drum	A3 646 26.0
		Pointer	A3 424 97.2
		Tension spring (driving cable)	A3 646 35.0
	Dial overseas	A3 220 51.0	
	<u>Model -04</u>		
		Cabinet - 509	23 642 62.0
		Rear panel	A3 690 95.0
		Pointer	A3 690 79.0
		Knob - tuning - 509	23 608 88.0
		Knob - volume control - 509	23 608 89.0
		Lever knob - waverangeswitch - 509	23 608 90.0
		Dial - overseas	A3 220 52.0
<u>LOUDSPEAKER 9730 X</u>			
		Cone with coil	49 981 20.0
		Clamping ring	25 871 80.0
		Paper ring	28 451 26.1
		Linen disc	49 976 04.0
<u>TOOLS</u>			
		Service oscillator	GM 2882
		Universal measure apparatus	GM 4256 or GM 4257
		Trimming transformer	E4 848 03.0
		Celluloid	09 994 15.0
		Glue	A9 863 54.0
		Vaseline compound	X 007 14.0

BX297U

WEERSTANDEN - RESISTANCES - RESISTANCES - WIDERSTÄNDE

R1	1000	Ohm	48 427 10/1K	R13 *	47000	Ohm	48 425 10/47K
R2	280	Ohm	49 379 62.0	R14	0,45	MOhm	49 500 34.0
R3	430	Ohm		R14a	0,05	MOhm	
R4	200	Ohm	49 364 63.0	R15	10	MOhm	48 427 10/10M
R5	180	Ohm		R16	0,47	MOhm	48 426 10/470K
R6	10000	Ohm	48 425 10/10K	R17	0,82	MOhm	48 425 10/820K
R7 *	47000	Ohm	48 425 10/47K	R18	130	Ohm	48 427 10/150E
R9 **	22000	Ohm	48 426 10/22K	R19 *	1000	Ohm	48 425 10/1K
R11 **	22000	Ohm	48 425 10/22K	R20			49 379 67.1
R12	2,7	MOhm	48 426 10/2M7	R21	56	Ohm	48 550 10/56E

CONDENSATOREN - CONDENSERS - CONDENSATEURS - KONDENSATOREN

C1	50	uF	48 317 58/50+50	C20	6,8	pF	48 406 99/68E
C2	50	uF		C21	30	pF	28 212 36.4
C3	12-492	pF	49 001 33.1	C22	2400	pF	48 429 02/2K4
C4	12-492	pF		C23	390	pF	48 406 02/390E
C5	1000	pF	48 757 20/1K	C24	115	pF	
C6	15	pF	48 406 20/15E	C25	115	pF	
C7	4700	pF	48 757 20/4K7	C26	47000	pF	48 751 20/47K
C9	47000	pF	48 750 20/47K	C27	102	pF	
C10	25	pF	49 005 49.0	C28	102	pF	
C11	25	pF	49 005 49.0	C29	3900	pF	48 751 20/3K9
C12	25	pF	49 005 49.0	C30	82	pF	48 406 10/82E
C13	330	pF	48 406 05/330E	C31	390	pF	48 406 10/390E
C14	22000	pF	48 752 20/22K	C32	6800	pF	48 751 20/68K
C15	82	pF	48 601 10/82E	C33	100	uF	48 313 22/100
C16	18000	pF	48 750 20/18K	C34	22000	pF	48 757 20/22K
C17	220	pF	48 601 10/220E	C35	100	pF	48 406 10/100E
C18	400-575	pF	49 005 55.0	C36	47	pF	48 605 10/47E
C19	15	pF	48 601 99/15E				

SPOELEN - COILS - BOBINES - SPULE

S1 )	1,1	Ohm		S15 )	3	Ohm	
S2 )	<1	Ohm		S16 )	4,5	Ohm	
S3 )	3,8	Ohm		S17 )	3	Ohm	A3 121 94.1
S4 )	<1	Ohm	A3 122 96.0	S18 )	4,5	Ohm	
S5 )	48	Ohm		C24 )			
S6 )	4,2	Ohm		C25 )			
S7 )	<1	Ohm					
S8 )	<1	Ohm		S19 )	2,4	Ohm	
S9 )	<1	Ohm		S20 )	9,5	Ohm	
S10 )	<1	Ohm		S21 )	2,4	Ohm	
S11 )	<1	Ohm	A3 122 97.0	S22 )	9,5	Ohm	A3 123 23.0
S12 )	2,6	Ohm		C27 )			
S13 )	6,8	Ohm		C28 )			
				S23 )	350	Ohm	
				S24 )	<1	Ohm	A3 128 88.0
				S26 )	18	Ohm	
				S25 )	3	Ohm	49 981 20.0

In later series replaced by:  
Reemplazados en la ultima serie por:

\* 48 550 10/...  
\*\* 48 552 10/...

BX 297U

I

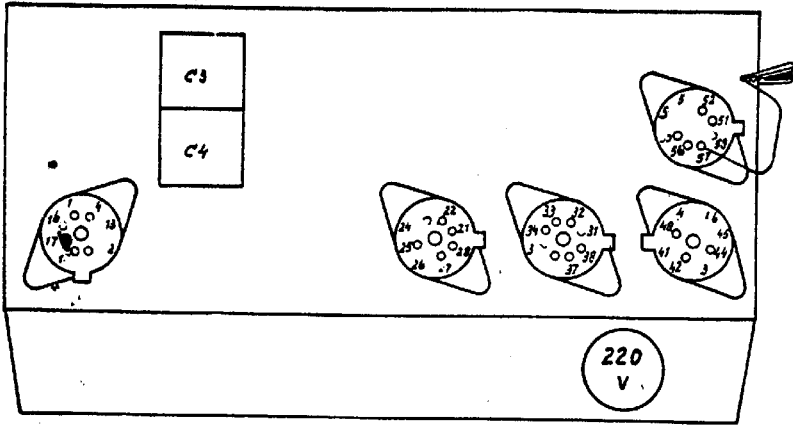

R12233

R

9	16	23	26	32	33	46													
	55	210	55	225	20	160													
10	13	14	15	25															
	230	150	230	230															
11	47	12	22	42	45	47													
	210	420	420	320	420	210													
12	17	24	27	31	34	35	36	37	57										
	10	10	10	10	10	10	10	10	10										
12																			

C

9	45	4	57							1	15	25							
	480	480	480								240	240							
10	42									12	32								
	25										105								

R 575 14 GM4256

R12231

# BX 297U

II

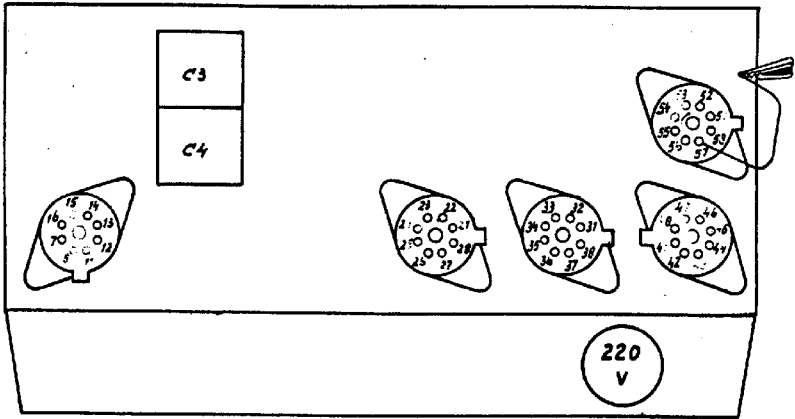

R12233

Ω	x 1	17	24	27	37	34	35	36	37	57								
		495	495	495	495	495	495	495	495	495	495							
	x 1																	
	x 10	47																
		130																
	x 10 <sup>2</sup>	12	22	42	45	47												
		170	170	295	170	390												
	x 10 <sup>3</sup>																	
	x 10 <sup>4</sup>	13	14	15	25													
		350	260	350	350													
	x 10 <sup>5</sup>	23	32	46														
		250	260	195														
	5x10 <sup>5</sup>	16	26	33														
		220	22	100														

μF	x 10 <sup>-3</sup>	32								x 1	42							
		200									160							
	x 10 <sup>-2</sup>	15	25							x 10	45	47	57					
		330	330								225	375	255					
	x 10 <sup>-1</sup>																	

R: 57 74 GM4257

R12232



BX 297 U

III

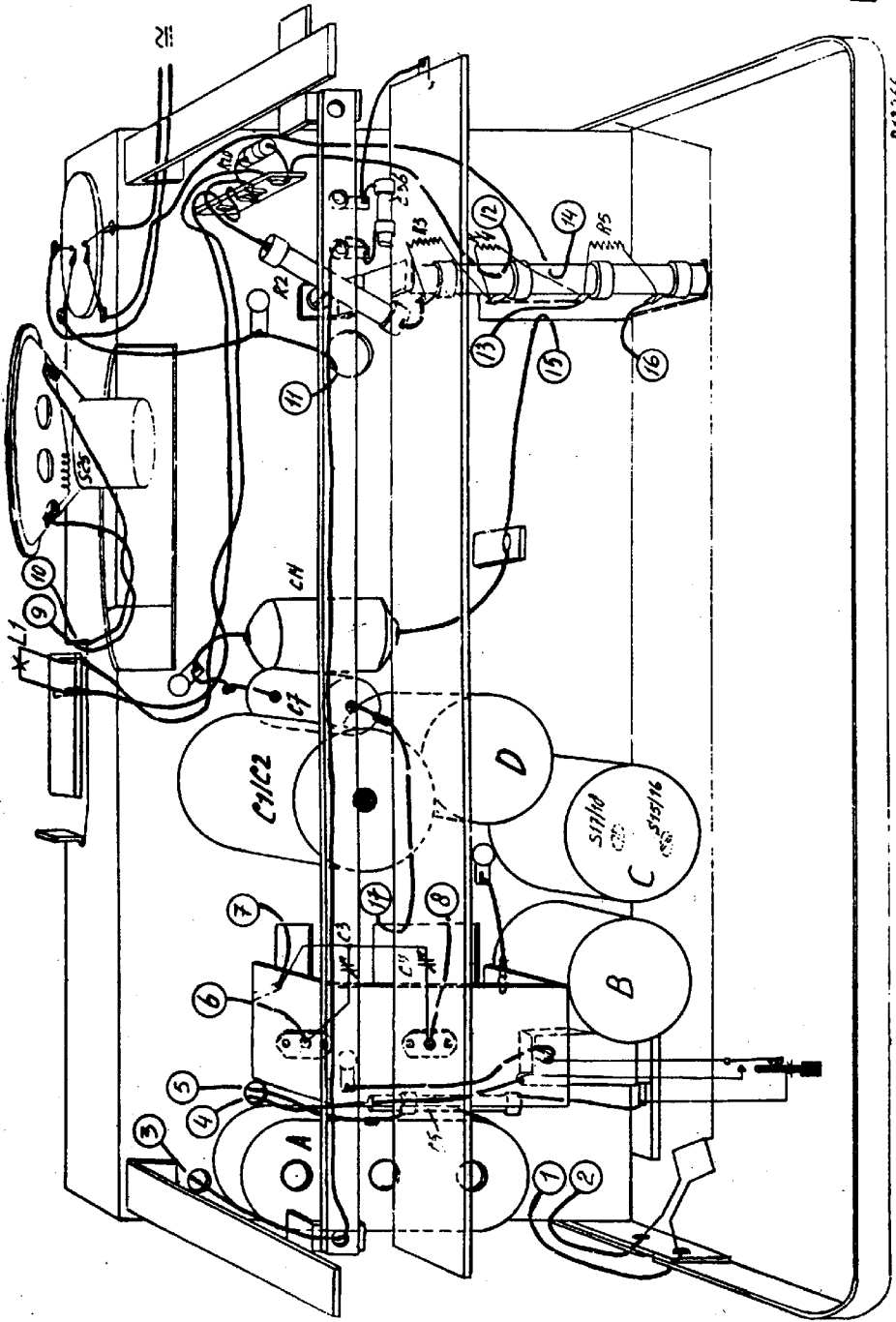

R12266

BX 297U

S	1,3,5,2,4,6,7	5,10,12,9,11,13	15,16,17,18	19,20,21,22	23,24,26,25
C	5,3,6,7,35	1,16,17,2	10,11,12,13,14	15,16,17,18	19,20,21,22,23,24,25
R	2,9,20,4,5	7,7,9	11,12	6,13,14,15,18	16,17,14,10

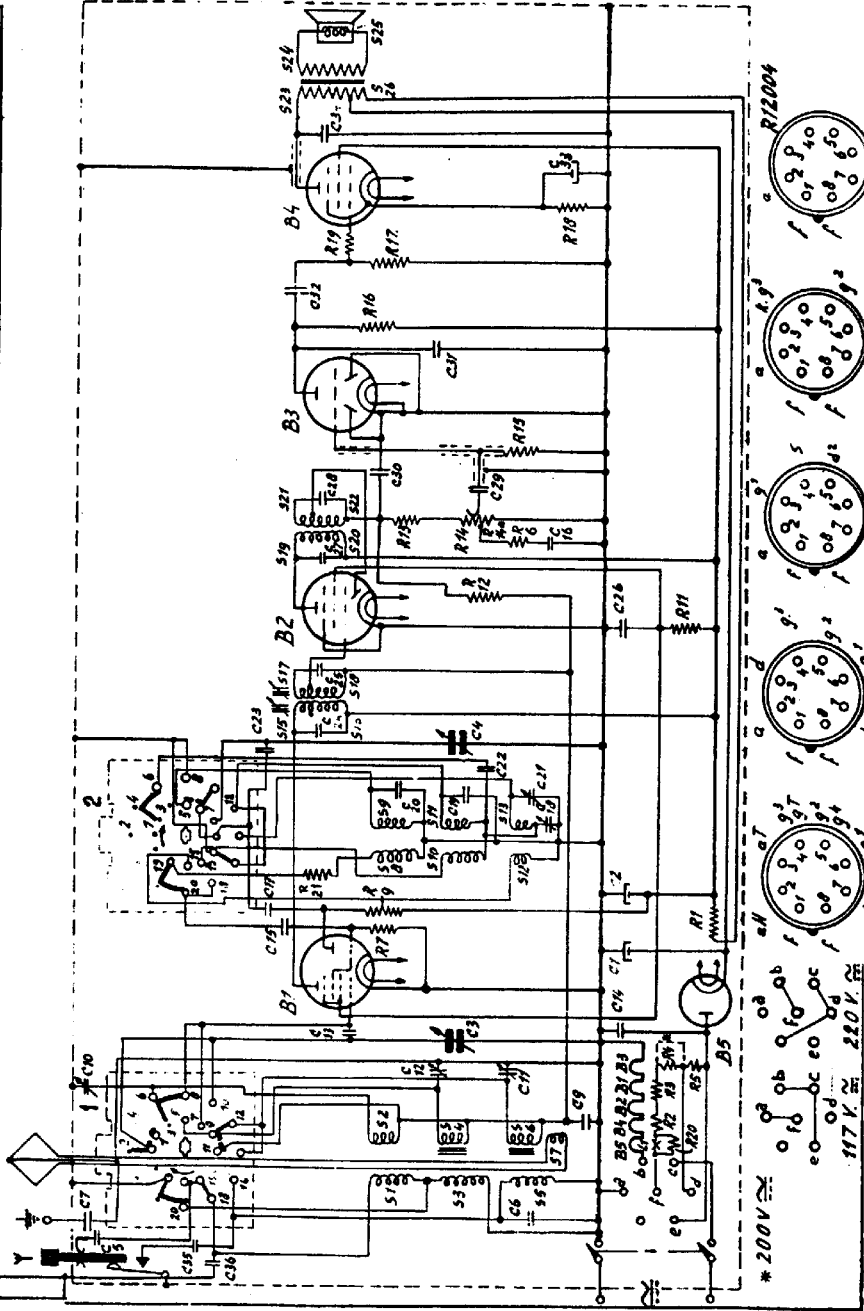

- \* 200V
- 117V 250V 220V
- B1: UCH 42
- B2: UAF 42
- B3: UBC 42
- B4: UAF 42
- B5: UCH 42
- R12004

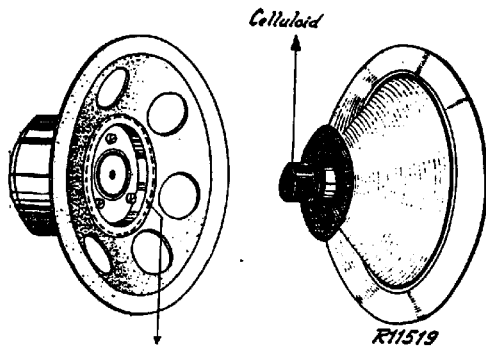

LIJM - COLLE - GLUE - LEIM - COLA

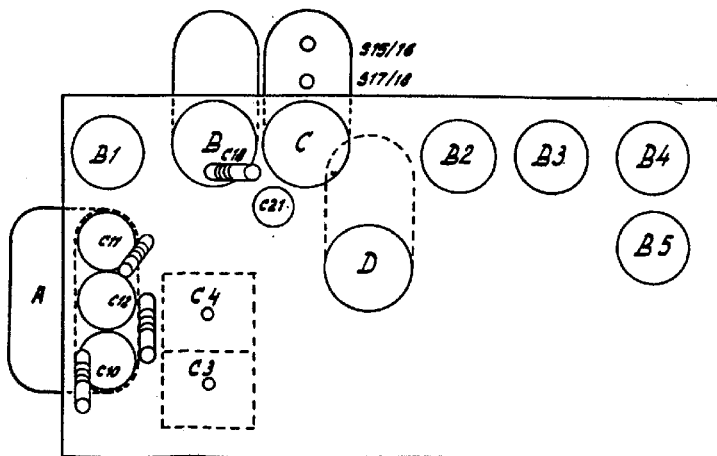

R12076

Fig 5

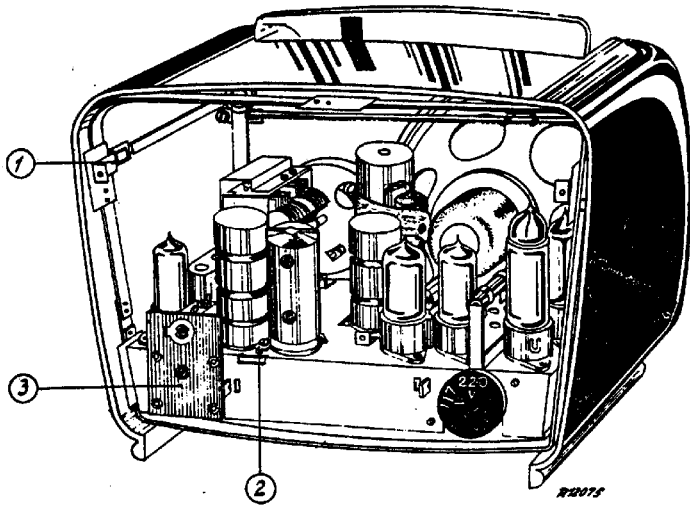

Fig. 6

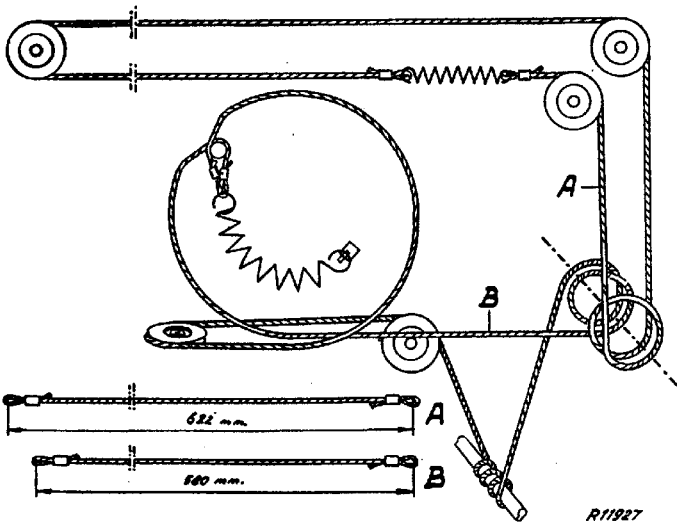
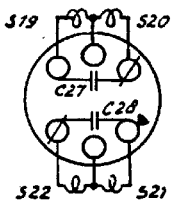
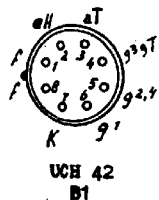
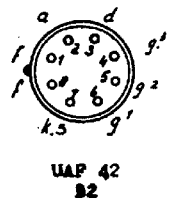
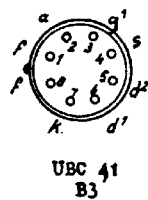
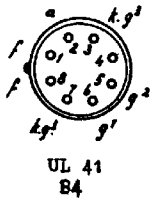
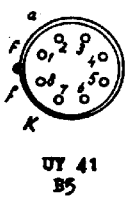
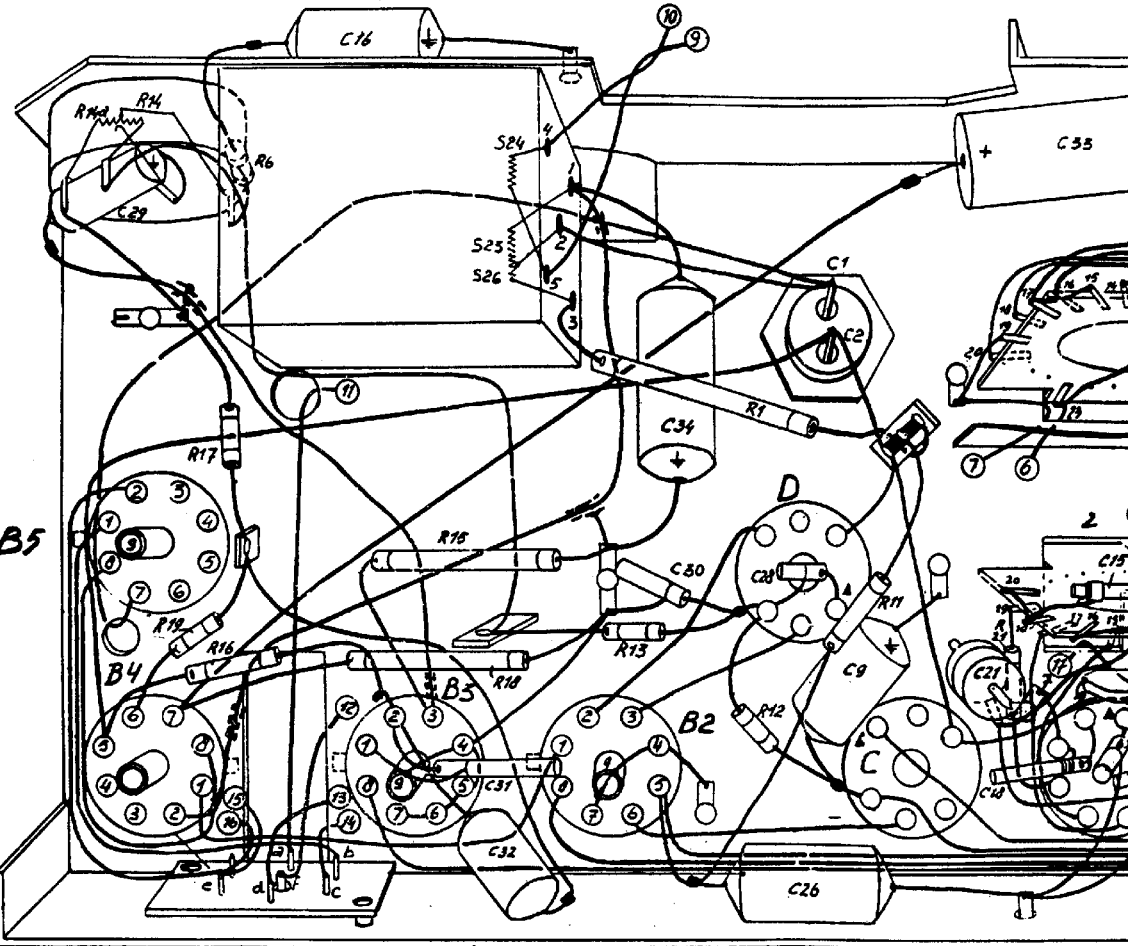

Fig 7

# BX297U

S:				D.	C.	B.
C: 29	16.	31,32.	30.	34.	20,26,129.	15,21.
R: 144,14,19.	6.	17,16.	18.	15.	13,1.	12.
						11.
						21



# BX 297U

V

	D	C	B	A
2.	34, 28, 26, 1, 2, 9	15, 21	33, 18, 10, 20, 22, 19, 23, 13, 17, 10, 12, 11, 35, 6	
1.	12	11	21	9, 7

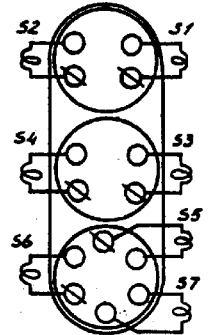
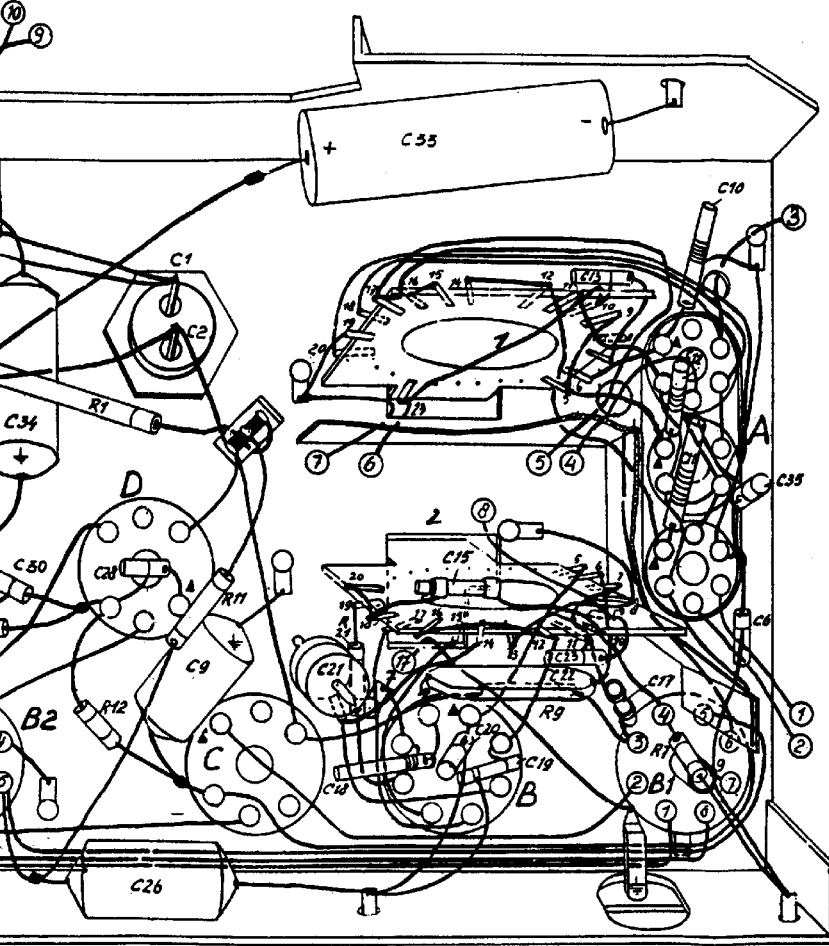

R12067

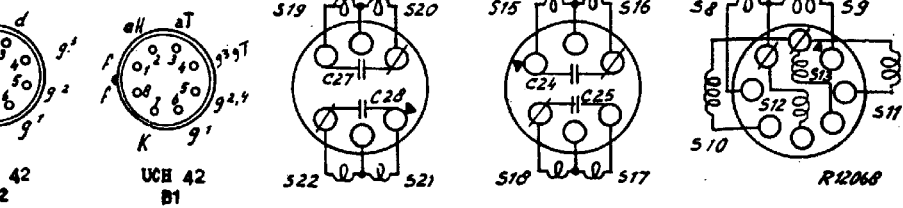

19759

S: 24, 25, 26.  
 C: 29.  
 R: 15, 14a, 14, 17, 6, 16, 17, 10, 31, 32, 30, 34, 13, 1, 12.

- 3 Verb. 8044W voor draag van felsmoer monteren.
- 5 Verb. 110 en 109 b van elkander verwijderd houden.
- 6 Verb. 113W tegen zijkant montageplaat monteren.
- 7 Verb. 110g verwijderd houden van P.spoel G.
- 8 Uitloper van C32 mag niet verbogen worden.

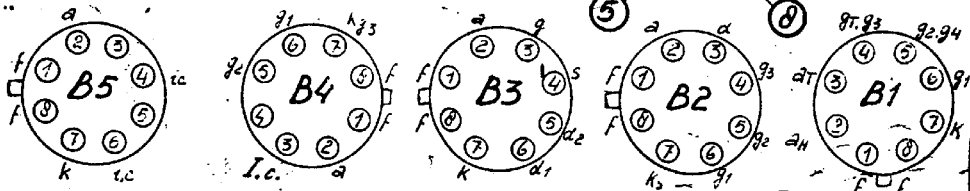
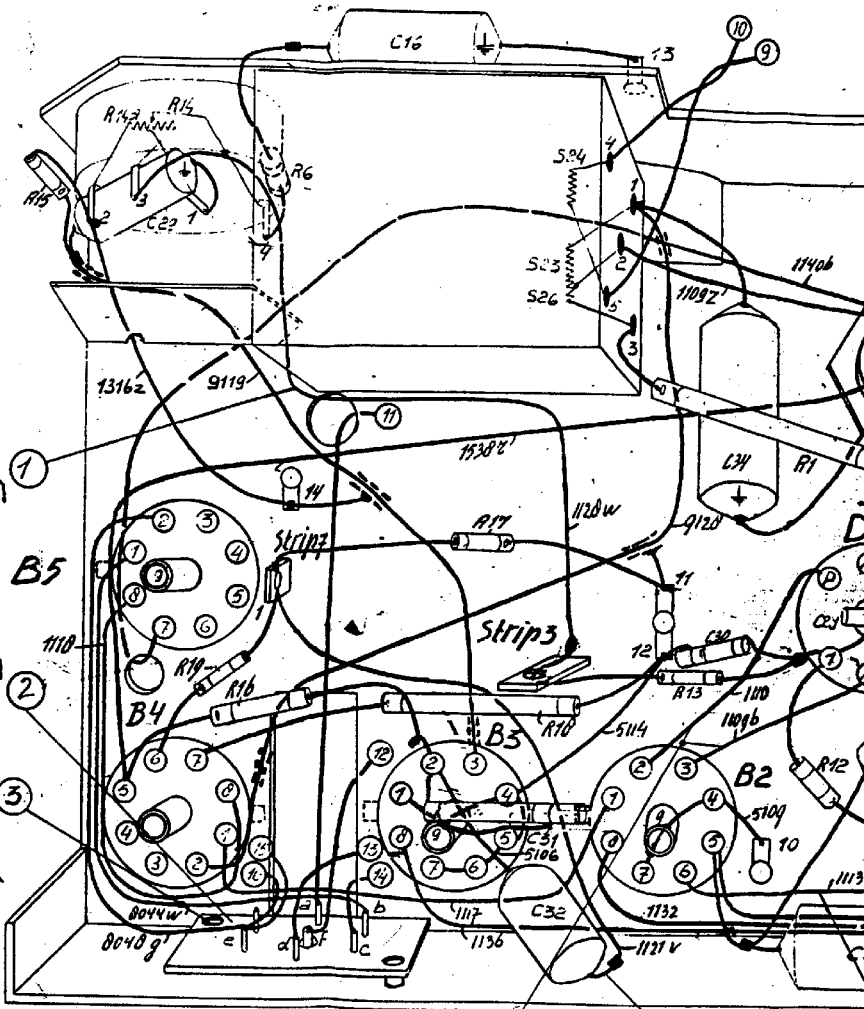

- 1 Verbindings luidsprekertrafo leggen.
- 2 Verb. van aansluitplaat zo dicht mogelijk hiertegen aan drukken.

a.d. verb.lijst:   
 d.d. principeschema: 23-50

④ *Bundel verb. Wegbuigen van sch.*

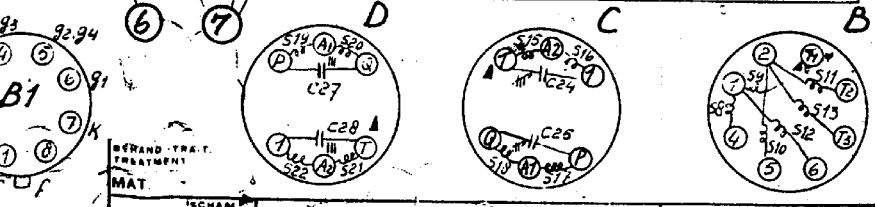
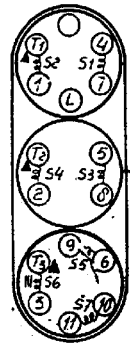
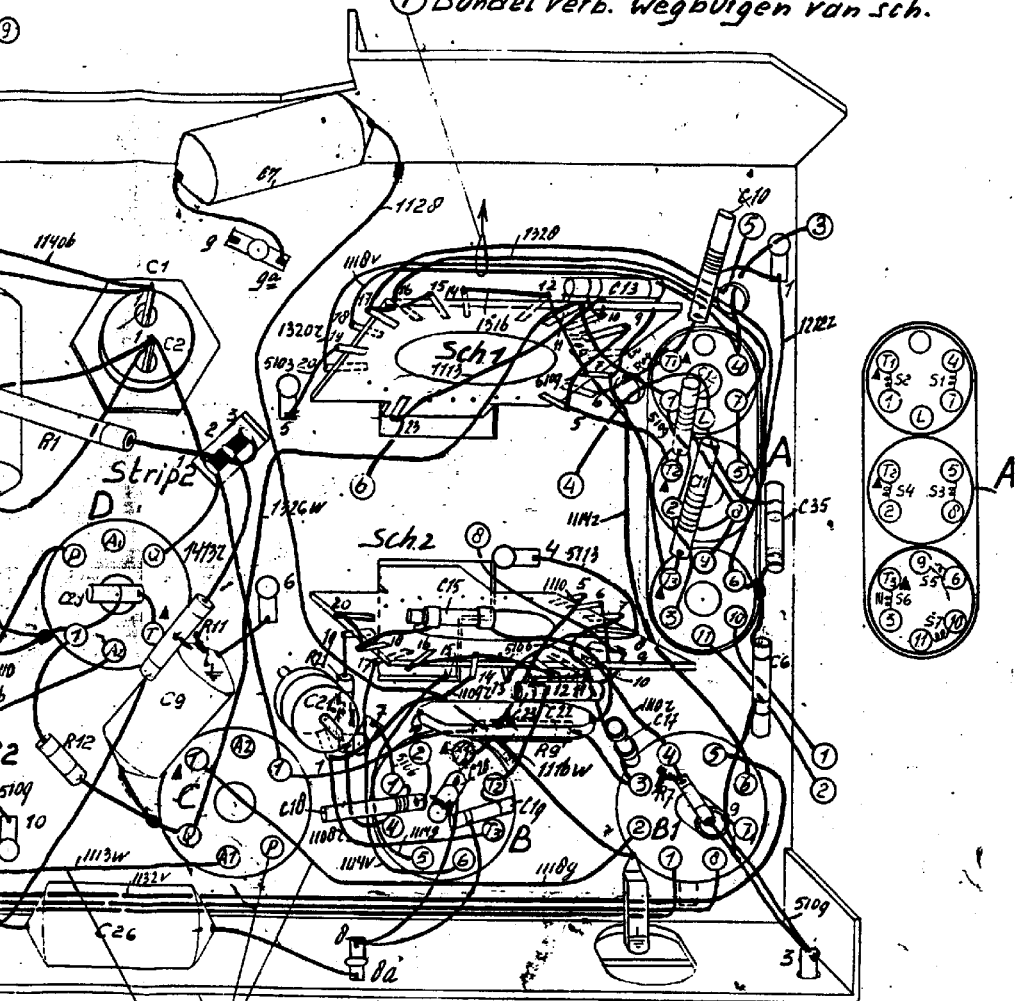

<p>BEFRAND. TRAIT. TREATMENT</p> <p>MAT</p> <p>BEWERTUNG. BEZ. DRAWN. UDF. MARK. OPERATION</p>	<p>SCHAAL. MASSST. SCALE</p> <p>BEWERTUNG. BEZ. DRAWN. UDF. MARK. OPERATION</p>	<p>Ontvanger 49150</p> <p>Montageschema</p>	<p><b>BX 297U</b></p> <p>22 1/2 201. 1047. 6-1-49</p> <p>V. Gent</p>	<p>10-150</p> <p>20-150</p> <p>20-150</p> <p>27-150</p>
------------------------------------------------------------------------------------------------	---------------------------------------------------------------------------------	---------------------------------------------	----------------------------------------------------------------------	---------------------------------------------------------